

GRAVEL/ SAND FILTERS – Series 4000

GENERAL INSTRUCTIONS

This filter has been designed and manufactured to achieve the highest standards of quality and finish.

This media filter uses gravel (or sand) as a bed that captures the suspended matter in the water that flows through it.

Media filters are particularly effective for filtering algae, organic matter and recycled water.

ODIS media filters (series 4000) use a unique design of a double bottom chamber, divided by a welded reinforced steel plate, which is suitable in particular for back-flushing.

For best results, the filter must be installed, operated and maintained according to the following instructions. Special attention must be given to proper back flushing at the specified periodic intervals, chlorination at the beginning and at the end of the season and to appropriate maintenance.

INSTALLATION

- Install the gravel filter in its chosen place.
- Assemble the valves and connect it to water. (See Fig. 1, 2 & 3 for water connections).
- Special attention must be given to correct flow direction.
- If more than one filter is installed, (filter arrays) leave sufficient space between the units to facilitate the maintenance.
- Specially designed **ODIS** manifolds (series 9000) are available for mounting multiple filter arrays.
- If the pressure is not controlled effectively a pressure relief valve must be installed before the filter installation.

NOTE: In automatic back flushing systems, install hydraulically operated valves with a response of less than 5 seconds to full opening or closing position.

- Fill the filter through the upper filling port with the proper quantity of media (see page 4).

NOTE: If the distributor does not supply the media, refer to “recommended media” for information.

- Close the top filling port with its cover, and tighten the bolts or mount the tightening bracket (2) and tighten the handle (1) according to the filter’s type.
- Verify that all the service covers, the valves and the accessories are closed tightly.
- Open the inlet valve and check for leaks.
- Back flush the filter with the new media, (refers to “beck flushing a single filter”) for at least two minutes, to wash out dirt and dust.
- Before operation, back flush the filter to verify its proper functioning. This step is **of vital importance** for effective use of the filter:
 - a. Filter with FLV * (Flow Limit Valve)- Check all hydraulic connections before back flushing (Fig 2).
 - b. Filter with a throttling valve-open the valve (F) during back flushing then close it gradually/ slowly, until no media is lost in the outgoing water flow. (Fig 1).
 - c. Filter with an automatic control – verify that the controller is set as follows:
 - 1) Backup Time - set backup time (time between flushings) to maximum of 3 hours (dirty water typically 1 – 2 hours).
 - 2) Dwell Time – Set dwell time (duration of flushing), typical dwell time:
For : 2” valve - 40-60 seconds, 3” valve - 50-70 seconds and 4” valve - 60-90 seconds.

Gravel filling

Model	Inlet/outlet Diameter	Gravel filling	
	inch	(kg)	(lbs.)
4121	1”	50	110
4162 (41615)*	2” (1½”)	75	165
4202	2”	125	275
4203	3”	125	275
4242	2”	175	385
4243	3”	175	385
4303	3”	250	550
4363	3”	350	770
4484	4”	625	1380
4363U	3”	300	660
4484U	4”	575	1270
4604/4604U	4”	1000	2200

* Filters 4162 & 41615 are the same, except for the difference in inlets and outlets diameters.

*The Flow Limiting Valve is an automatic flow regulator which closes when pressure increases, to keep the back flush flow rate constant.

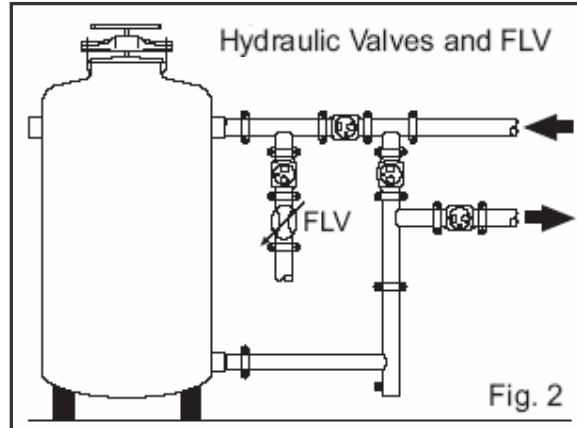
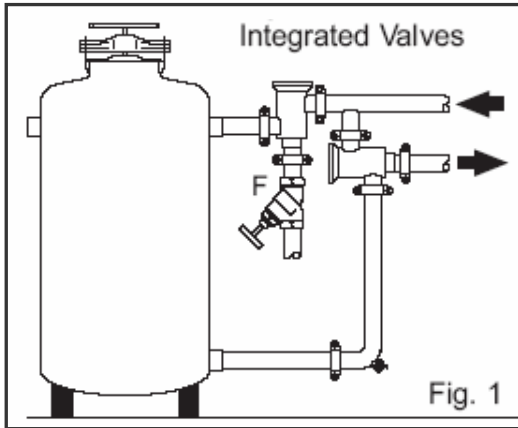

OPERATION

- Maximal operation pressure should not exceed 8 bar (120 psi).
- The filter is designed to withstand a maximum pressure of 10 bar (150 psi).
- Head-loss should not exceed 0.7 bar (10 psi)!
- Normal working conditions are obtained when head loss is less than 0.3 bar (4.5 psi) with a clean filter.
- If head loss exceeds 0.3 bar (4.5 psi) – filter is either partially clogged or operating under an excessive flow rate.

NOTE: For arrays operation instructions see arrays operation manual.

- Back flush the filter at the beginning and at the end of irrigation.
- Chlorinate the filter before end of irrigation, as necessary.
- Back flush filter when head loss increases by 0.3 - 0.5 bar (4.5 – 7.5 psi) above head loss of clean filter, or every 3 hours, whichever comes first.
- Verify the filter head loss by measuring pressure difference with the installed pressure gauge and the 3 way valve selector.
- Automatic back flushing by an irrigation controller is recommended.
- For recommended flow rates for filtering and back flushing, see the table on page 3.
- If the filter’s gravel is contaminated by organic particles, chlorination should be performed.
- Chlorinate the filter at the beginning and at the end of the irrigation season.(see clause “Chlorination”)

WARNING: Do not tighten or open the covers during operation or under pressure.

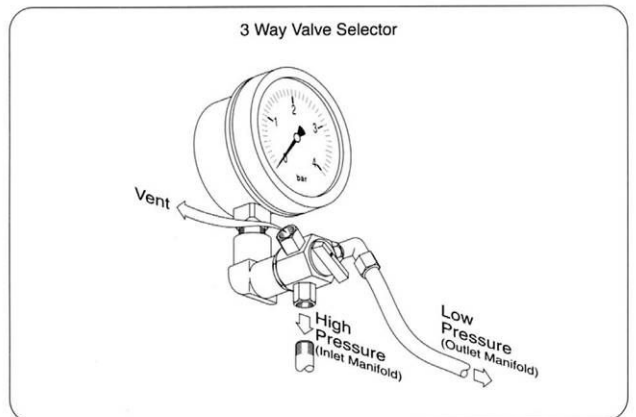
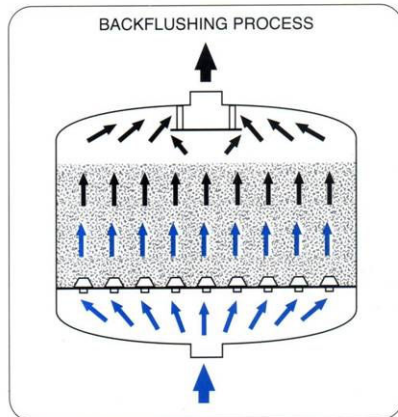
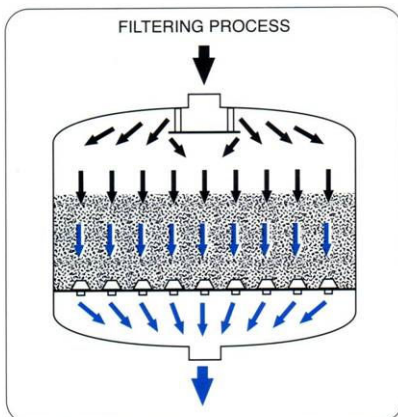

Operating scheme

Manometer and a 3-way selector



BACK-FLUSHING OF A SINGLE FILTER

- During normal filtering (irrigation), valves A and B are open, while valves C and D are closed, (valve C is a throttling valve) - see fig. 3.
- **Back flushing of filter (manual):**
 - a. The filter must be back flushed periodically according to water quality, the water flow and the field conditions.
 - b. Close valves A and B, (see fig. 4), then open valves C and D (see note). Back flush for 45 to 90 seconds (see fig. 4). (For automatic back flushing, time is reduced for minimum of 30 seconds).
 - c. Return to normal filtering (see fig. 3)

NOTE: If a Flow Limiting Valve is not installed, open throttle valve C, so that no gravel/sand is lost during the back flush and the flow is good (see “installation”) when the valve is “open”.

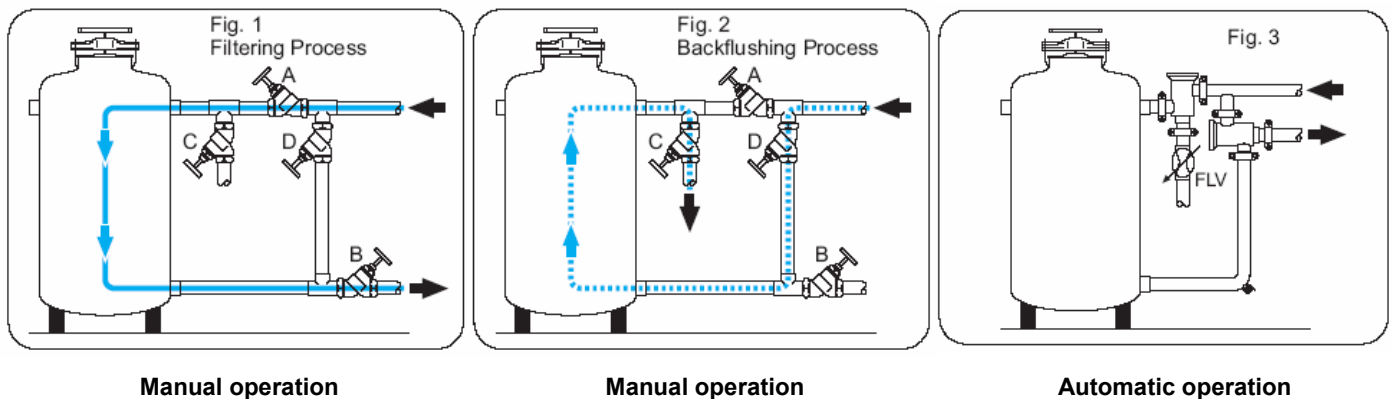

Recommended Flow Rates

Metric Units/ U.S. Units

Models	Inlet / Outlet Diameter		Body Diameter		Recommended Flow Rate ***							
					Minimum		Average*		Maximum		Back Flushing	
	inch	mm	inch	mm	m ³ /h	U.S. gpm	m ³ /h	U.S. gpm	m ³ /h	U.S. gpm	m ³ /h	U.S. gpm
** 4121	1"	25	12"	300	3.5	15	5	22	6	26	7	31
4162	2"	40	16"	400	6	26	8	35	11	48	10	44
4202	2"	50	20"	500	9	40	12	53	18	80	15	66
4203	3"	80	20"	500	10	44	12	53	18	80	15	66
4242	2"	50	24"	600	14	62	20	88	28	123	25	110
4243	3"	80	24"	600	14	62	20	88	28	123	25	110
4303	3"	80	30"	750	21	92	30	132	42	185	38	167
4363	3"	80	36"	900	32	141	42	185	62	273	54	238
4484	4"	100	48"	1200	62	273	72	317	120	528	95	418
4604	4"	100	60"	1500	80	352	110	485	150	660	150	660
4363U	3"	80	36"	900	32	141	42	185	62	273	54	238
4484U	4"	100	48"	1200	62	273	72	317	120	528	95	418
4604U	4"	100	60"	1500	80	352	110	485	150	660	150	660

* Average water quality. For dirty water reduce the flow rate.

** Available with 1½" Inlet Outlet (Model 41615).

*** For crushed basalt no. 1 or crushed granite no. 11.

(For crushed silica or quartz sand no. 16, use half flow rates).

PERIODIC CLEANING

- Close valves at the inlet and outlet of filters.
- Release pressure within the filter and open the top filling port.
- Inspect media level and its cleanliness.
- If the media is not effective anymore (long usage, or tough caking), replace the media, see “replacing the filter’s media”.
- Check the valves. Check the Flow Limiting Valve or throttling valve.

MAINTENANCE

- Each filter is supplied with instructions for maintenance, installation and operation.
- Perform monthly periodic checks.
- Once a week perform a manual back flush, make sure that the differential pressure is below 0.25 bar (4 psi), after the back flush.
- Once a year spread a layer of grease on the top cover's handle threads.
- Special coating protects all **ODIS** products; any damage to the protective coating of the equipment must be repaired without delay. Prior to the application of the protective paint, clean thoroughly the damaged areas with a wire brush.
- Replace batteries in the controller, if applicable, with fresh ones at the beginning of the irrigation season.
- Before installing back bolts, spread bolts threads with thin layer of grease.

NOTE: Any damage to the equipment protective coating must be repaired without delay. Prior to application of protective paint, clean thoroughly the damaged area with a wire brush.

FILLING / REPLACING THE FILTER’S MEDIA

- NOTES:** 1. prior to media filling verify that all conical diffusers set on the distribution plate are installed and are intact. (**Do not use filter in case of absence or damage of conical diffusers!!!**)
2. The filter media will be filled only after leakage checking.

- Close filter's inlet valve
- Empty water from the filter; open the upper filling cover of the gravel media filter. See parts no. 3 or 10, in the “Detailed parts scheme”.
- Fill the gravel media through the top port of the filter, according to recommended weights.

NOTE: The conical diffusers set on the double bottom must be totally covered by the gravel media.

- After having filled in the media layer, close the filling port and fasten it properly.

NOTE: In order to receive efficient filtering results, in case the media layer is not supplied by **ODIS** - care should be taken to see that the media layer particles, should have sharp edges, its minimal grain size – 0.6 mm; maximal unity coefficient - 1.5.

Replace the gravel when the amount of dirt (that cannot be back flushed), prevents proper functioning of the filter.

- Close all the valves.
- Open the filter drain plug, to release the pressure and to drain all the filter’s water.
- Open the top filling port.



- Open with care the side service ports.
- Empty the gravel from the filter, through the side service ports.
- Rinse the interior thoroughly with clean water.
- Inspect the double bottom of the filter including the partition and the “mushrooms” diffusers.
- Check the protective coating for damage and repair if necessary.
- Close the side service ports with covers and tighten properly.
- Fill the filter through the top filling port with the right amount of gravel - (see installation).
- Check the Flow Limit Valve, or readjust the Throttle Valve (F) – (see installation).
- Back flush the filter with the new gravel to wash out dirt and dust, for at least two minutes.
- Open the valves for normal operation – (see installation)

Recommended media for standard usage:

Media type	Particle size	Filtration rate m ³ /h /m ²	
	mm	During filtration	During back-flushing
Crushed granite no. 11	1.2 – 1.8	50 - 75	85
Crushed basalt no. 1	1.2 – 1.8		
*Crushed silica no. 16	0.8 – 1.2	30 - 40	40

← Recommended Media

***When using Crushed silica media, filtration rate is reduced.**

NOTES:

- For efficient filtration the media should be crushed with sharp edges,.
- Flow recommendation according to dirt load (for crushed granite and crushed basalt):
 1. 75 m³/h/m² (30 gpm/ft²) for average water condition.
 2. 50 m³/h/m² (20 gpm/ft²) for dirty water.
- For special water conditions, e.g. iron content and recycled water, other media types are available at lower flow rates – please consult our service department or your distributor.
- Minimum media grain size: 0.6 mm.

CHLORINATION

At the beginning of the irrigation season chlorinate and back-flush as follows:

- Empty the filters from water, up to a level of about 10 centimeters above the media layer surface, and add liquid Sodium Hypochlorite (NaOCl), according to filter size (see the table below) then fill the filter with water. The concentration will be the required one,,: 80 –100 ppm.
- Wait for 30 minutes (with no water flow) then back flush the filter.

At the end of the irrigation season chlorinate as noted above (At the beginning of the irrigation season):

- Chlorinate during an irrigation interval approx. 1 hour before irrigation ends.
- Back flush the filter 2-3 times; 2 minutes every time, then complete the irrigation as planned. (This will get rid of the chlorine residues.
- Drain all the water from the filter, open the top service port and leave it to dry up.
- When the media is dry, close all openings and valves until the next irrigation season.

Type of Hypochlorite	Quantity			
	Household Bleach (3%)		Commercial (10%)	
Models	Liters	Fluid Oz	Liters	Fluid Oz
4121	0.210	7	0.060	2.0
4162, (41615)	0.370	12	0.110	3.7
4202	0.550	18	0.170	5.7
4203	0.650	22	0.200	6.8
4242	0.830	28	0.250	8.5
4243	0.830	28	0.250	8.5
4303	1.150	39	0.320	10.8
4363	1.600	54	0.480	16.2
4484	3.000	101	0.900	30.4
4363U	1.450	49	0.430	14.5
4484U	2.650	90	0.800	27.1
4604/4604U	4.700	159	1.410	48.0

1 US Gallon = 3.7854 liters.

1 US Gallon = 4 quarts = 8 pints = 128 fluid ounces (Oz).

1 US Pint = 16 fluid ounces.

ILLUSTRATED PARTS BREAKDOWN

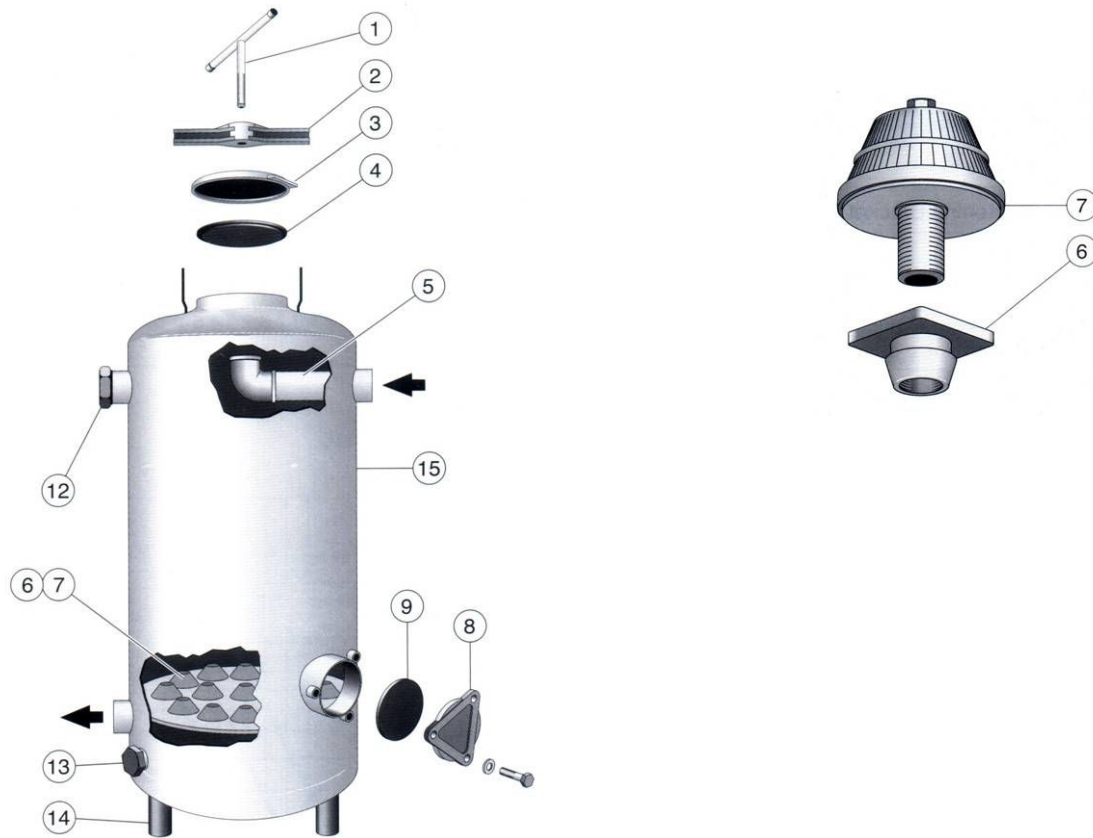

CATALOG NUMBERS

Part No.	Description	Model						
		4121(1")	41615(1½")	4162(2")	4202(2")	4203(3")	4242(2")	4243(3")
1	Handle	E000100	E000100	E000100	E000100	E000100	E000100	E000100
2	Tightening Bracket	E000216	E000218	E000218	E000218	E000218	E000218	E000218
3	Cover	E000260	E000280	E000280	E000280	E000280	E000280	E000280
4	Cover Gasket	E004365	E004380	E004380	E004380	E004380	E004380	E004380
5	Conduit	E405700	E405700	E410701	E410701	E405700	E420700	E420701
6	Rubber Bushing	E400720	E400720	E400720	E400720	E400720	E400720	E400720
7	"Mushroom" Diffusers	E400400	E400400	E400400	E400400	E400400	E400400	E400400
8	Service Opening Cover	E400240	E400240	E400240	E400260	E400260	E400260	E400260
9	Service Opening Cover Gasket	E001340	E001340	E001340	E004365	E004365	E004365	E004365
12	Male Plug	H070310 (1")	H070315 (1½")	H070320 (2")	H070320 (2")	H070320 (2")	H070320 (2")	H070320 (2")
13	Male Plug	-----	H070310 (1")	H070310 (1")	H070310 (1")	H070310 (1")	H070315 (1½")	H070315 (1½")
14	Rubber Leg	E004367	E004367	E004367	E004367	E004367	E004368	E004368
15	Filter Body	A4121	A41615	A4162	A4202	A4203	A4242	A4243

ILLUSTRATED PARTS BREAKDOWN

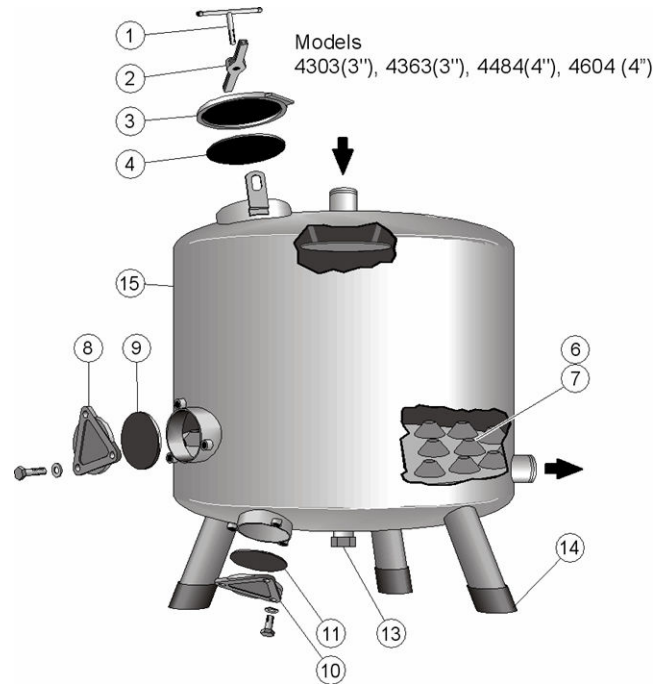
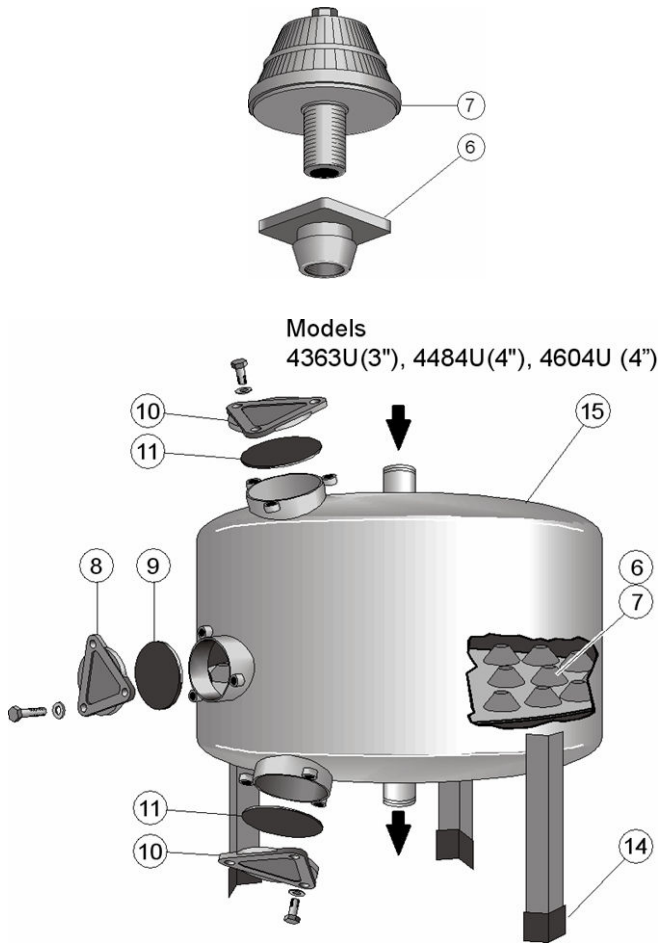

CATALOG NUMBERS

Part No.	Description	Model						
		4303(3'')	4363(3'')	4484(4'')	4604(4'')	4363U(3'')	4484U(4'')	4604U(4'')
1	Handle	E000100	E000100	E000100	E000100	-	-	-
2	Tightening Bracket	E000218	E000218	E000218	E000218	-	-	-
3	Cover	E001280	E001280	E001280	E001280	-	-	-
4	Cover Gasket	E004381	E004381	E004381	E004381	-	-	-
6	Rubber Bushing	E400720	E400720	E400720	E400720	E400720	E400720	E400720
7	"Mushroom" Diffusers	E400400	E400400	E400400	E400400	E400400	E400400	E400400
8	6" Service Cover	E400260	E400260	E400260	-	E400260	E400260	-
	8" Service Cover	-	-	-	E002280	-	-	E002280
9	6" Service Cover Gasket	E004365	E004365	E004365	-	E004365	E004365	-
	8" Service Cover Gasket	-	-	-	E004381	-	-	E004381
10	6" Service Cover	E400260	E400260	-	-	-	-	-
	8" Service Cover	-	-	E002280	E002280	E002280	E002280	E002280
11	6" Service Cover Gasket	E004365	E004365	-	-	-	-	-
	8" Service Cover Gasket	-	-	E004381	E004381	E004381	E004381	E004381
13	Male Plug	H070320	H070320	H070320	H070320	-	-	H070320
14	Rubber Leg	E004368	E004368	E004488	E004488	E004369	E004369	E004488
15	Filter Body	A4303	A4363	A4484	A4604	A4363U	A4484U	A4604U

20 Hayetsira St.. P.O.B. 3137 Kiryat Arye Petach Tikva 49130 ISRAEL
Tel. 972-3-9258500 Fax. 972-3-9249023 E-mail: odis@odis.co.il Web site: www.odis.co.il

Aimed at continued improvement, *ODIS* reserves the rights to change specifications without prior notice.