

ODIS

IRRIGATION EQUIPMENT LTD.

ODISMATIC® ELECTRIC FILTERS SERIES 863

APPLICATIONS

- Used as Economic Automatic Screen Filter for water containing large quantities of dirt.
- The filter contains an Electrically operated Collector with Suction Nozzles to ensure continuous trouble free operation.
- For: Irrigation, Water Recycling and Industry



ODIS Filtration *is The Heart* of Every Irrigation System

DESCRIPTION

The **OdisMatic® Electric Filter** Model 863 is an automatic self cleaning screen filter.

The Self Cleaning System is electrically operated and contains a suction system for cleaning the screen, an electric motor with a worm gear to drive the suction system in a helical movement, and a PLC (Programmable Logic Controller) to perform the cleaning process.

The cleaning process is short, efficient, saves water and leaves the screen clean.

Dirty water enters the filter and is pre-filtered through a coarse screen (1). The water then flows through a sintered multi layer stainless steel fine screen (2) and flows out through the outlet port. The dirt particles gradually build up a filter "cake" on the inside of the fine screen. This "cake" improves filtration efficiency as it performs a finer filtration, and creates a pressure differential across the screen. The differential pressure rises until the predetermined value is reached [normally 0.5 bar (7.5 psi)].

A pressure switch activates the self cleaning process. A timer backup guarantees that the time passed from the last self cleaning process will not be longer than the preset value determined by the user.

On a flushing command, the flushing valve (6) opens to the atmosphere and creates pressure drop in the flushing chamber (4) as well as in the collector pipe (7), causing the dirt to be sucked in from the screen by the nozzles (3) outward to drain through the collector (7) and the flushing valve (6).

Simultaneously the electric motor with the worm gear (5) creates a helical motion of the collector with the suction nozzles to "cover" the entire screen's surface, enabling complete and effective cleaning of the screen.

Available in the following inlet sizes: 2", 3", 4", 6", 8", 10", 12", 14".

Filter is supplied with Flanged Connection (F).

The filter has a 100 micron protective coating of extra durable polyester applied electrostatically and oven cured on a zinc-phosphate layer for maximal anti-corrosion protection.

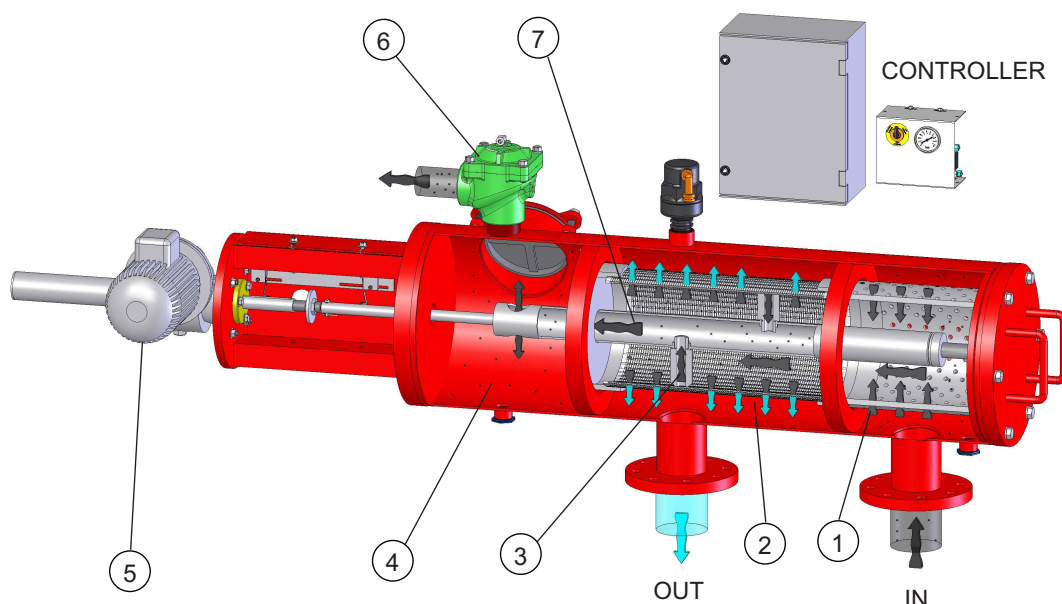

Dimensions & Weight Metric Units

Model	B		D	A	E	H	L	L1	Weight
	mm	inch	inch	mm	mm	mm	mm	mm	kg
86302	50	2"	12"	430	615	620	1905	2700	155
86303	80	3"	12"	430	615	620	1905	2700	160
86304	100	4"	12"	600	615	635	2155	3000	174
86306	150	6"	12"	600	615	635	2155	3000	180
86308	200	8"	16"	780	695	760	2395	3500	280
86310	250	10"	16"	780	695	760	2395	3500	290
86312	300	12"	16"	990	695	760	2685	3970	330
86314	350	14"	16"	990	695	760	2685	3970	355

Dimensions & Weight U.S. Units

Model	B	D	A	E	H	L	L1	Weight
	inch	inch	inch	inch	inch	inch	inch	lbs
86302	2"	12"	16.9	25	24.5	75	107	342
86303	3"	12"	16.9	25	24.5	75	107	353
86304	4"	12"	23.6	25	25	85	116	384
86306	6"	12"	23.6	25	25	85	116	397
86308	8"	16"	30.7	28	30	94	137	617
86310	10"	16"	30.7	28	30	94	137	640
86312	12"	16"	39	28	30	106	157	728
86314	14"	16"	39	28	30	106	157	782

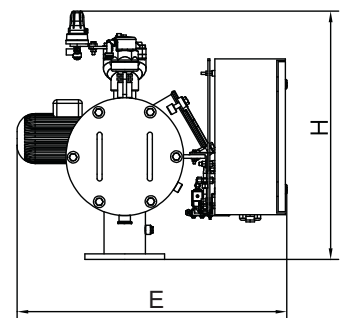
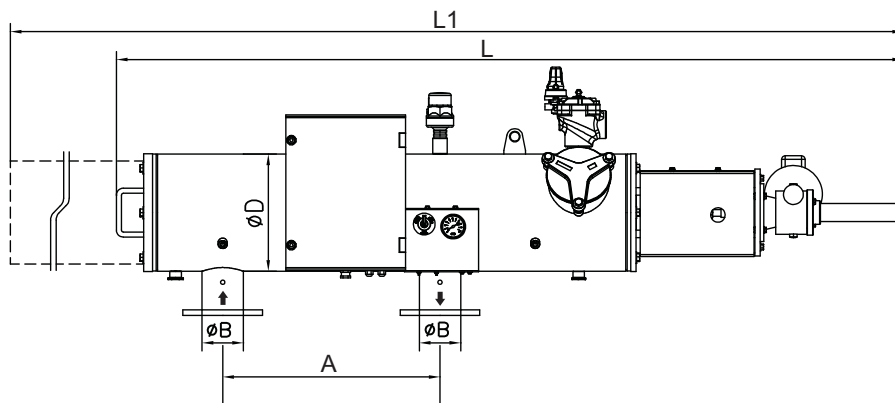

Screen Area & Recommended Flow Rates

Model	Inlet/Outlet diameter		Max. Flow Rate		Flushing Flow Rate		Screen Area	
	inch	mm	m ³ /h	U.S. gpm	m ³ /h	U.S. gpm	cm ²	sq.inch
86302	2"	50	25	110	16	70	2500	390
86303	3"	80	40	170	16	70	2500	390
86304	4"	100	80	350	16	70	4000	620
86306	6"	150	150	660	16	70	4000	620
86308	8"	200	300	1300	25	110	6000	930
86310	10"	250	400	1750	25	110	6000	930
86312	12"	300	470	2050	30	135	8000	1240
86314	14"	350	550	2400	30	135	8000	1240

- The max. flow rate refers to screens over 200 microns/less than 80 mesh.
For finer filtration degrees consult our representative.

Stainless Steel Filter Screens

Filtering Grades

Mesh Grade	Micron
40	400
50	300
80	200
100	150
120	120
150	100
200	80
300	50
500	30

- Coarse screen – Perforated cylinder.
- Fine screen – Multi layer stainless steel wire mesh sintered together.

Technical Data

- Max. recommended working pressure: 10 bar (150 psi).
- Min. recommended working pressure: 2 bar (30 psi).
- Two filtering stages:
 - Coarse Screen: Perforated cylinder, prevents large particles from entering the cleaning mechanism.
 - Fine Screen: Multi layer stainless steel wire mesh sintered together, stops the fine dirt particles.
- Wide range of screens down to 30 micron.
- Automatic self cleaning of the screen – activated by time elapsed or DP (differential pressure).
- Suction system with nozzles.
- Electric motor with worm gear – to drive the suction system in a helical movement on the screen
- PLC – to control the cleaning process.
- Electrical data :
 - Mains – 3 phase 380V/ 50Hz, 220V/440V/60Hz
 - Drive assembly – 1/3HP, 1/4 KW.
- PLC operated by 24VDC

Protective Coating

100 micron extra durable polyester, applied electrostatically and oven cured on a zinc phosphate layer for anti corrosion protection.

Pressure Relief Valve

A pressure relief valve must be inserted before the filtering installation if pressure is not controlled effectively.

- Each filter is designed and manufactured in order to achieve the highest standard of quality and finish.

HEAD LOSS/FLOW RATE
Metric Units
Head Loss **

Model	Flow Rate Q (m ³ /h)												
	15	20	25	50	75	100	125	150	200	250	300	350	400
	Head Loss dP (bar)												
86302 (2")	0.09	0.16	0.25	1.00									
86303 (3")			0.05	0.21	0.46	0.83							
86304 (4")				0.07	0.16	0.28	0.44	0.64	1.13				
86306 (6")						0.06	0.09	0.12	0.22	0.35	0.50	0.68	0.89

Model	Flow Rate Q (m ³ /h)												
	200	300	400	500	600	700	800	900	1000	1200	1500	1800	2000
	Head Loss dP (bar)												
86308 (8")	0.08	0.17	0.30	0.47	0.68	0.92	1.20						
86310 (10")		0.07	0.13	0.21	0.30	0.40	0.53	0.67	0.83	1.19			
86312 (12")			0.07	0.11	0.15	0.21	0.27	0.34	0.42	0.61	0.95		
86314 (14")				0.06	0.09	0.12	0.15	0.19	0.24	0.35	0.54	0.78	0.96

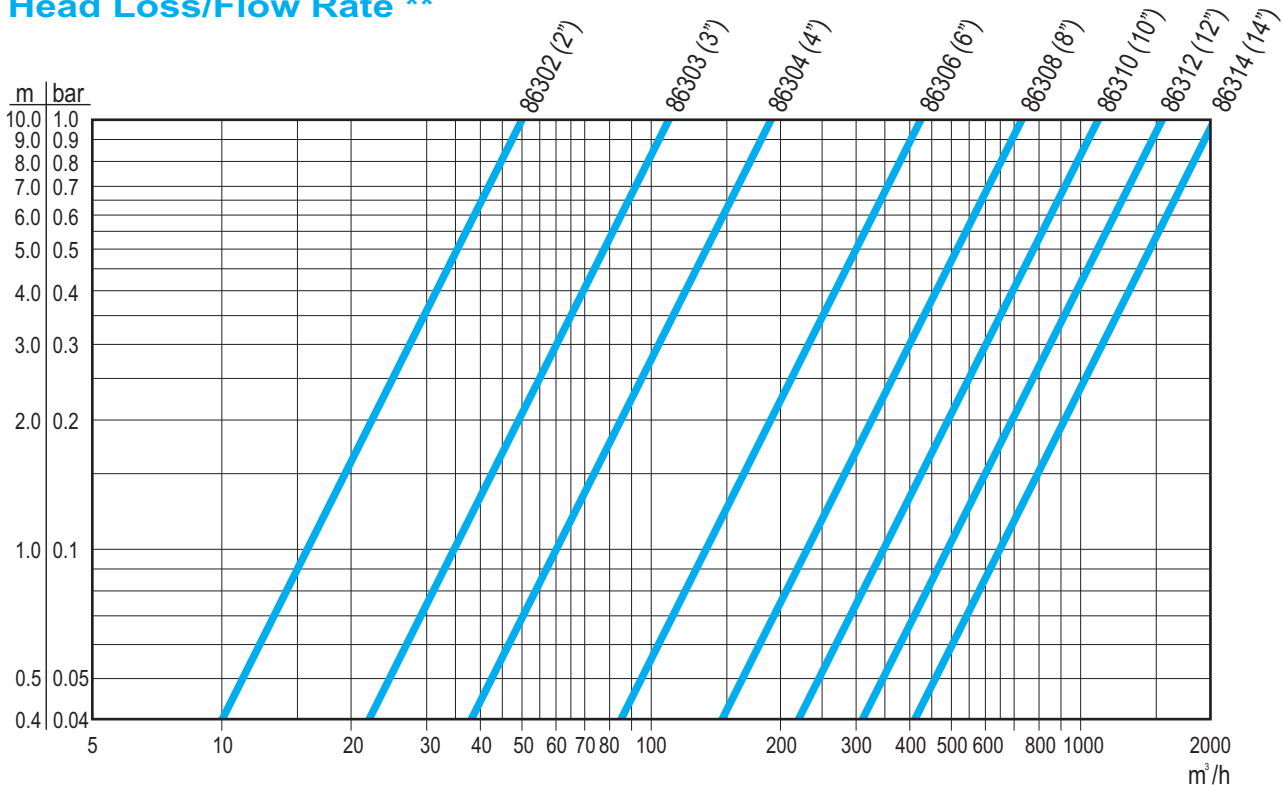
Head Loss/Flow Rate **

** For a clean filter and 120 mesh screen.

■ 1 bar=100 kPa=1.02 kg/cm²=10.2 m (W.C)=14.5 psi

HEAD LOSS/FLOW RATE

U.S. Units

Head Loss **

Model	Flow Rate Q (U.S. gpm)												
	50	90	120	200	300	450	600	700	900	1100	1300	1500	1800
	Head Loss dP (psi)												
86302 (2")	0.7	2.4	4.3	12.0									
86303 (3")		0.5	0.9	2.5	5.6	12.5							
86304 (4")				0.8	1.9	4.3	7.6	10.4	17.1				
86306 (6")						0.8	1.5	2.0	3.4	5.0	7.0	9.3	13.4

Model	Flow Rate Q (U.S. gpm)												
	900	1300	1500	1800	2000	2600	3000	3500	4000	4500	5000	6500	8000
	Head Loss dP (psi)												
86308 (8")	1.1	2.4	3.2	4.5	5.6	9.5	12.6	17.2					
86310 (10")	0.5	1.0	1.4	2.0	2.5	4.2	5.6	7.6	9.9	12.5	15.5		
86312 (12")		0.5	0.7	1.0	1.3	2.1	2.8	3.9	5.0	6.4	7.9	13.3	
86314 (14")				0.6	0.7	1.2	1.6	2.2	2.9	3.6	4.5	7.6	11.5

Head Loss/Flow Rate **

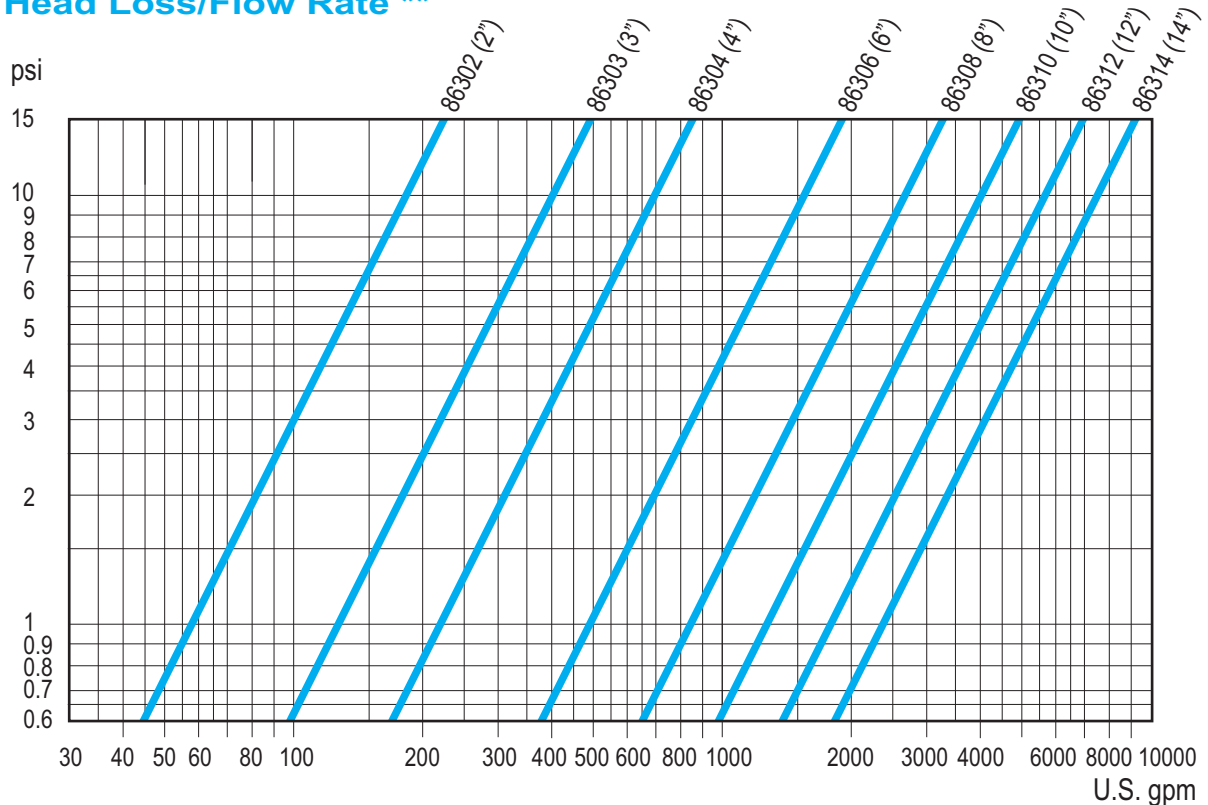

** For a clean filter and 120 mesh screen.

■ 1 psi=0.069 bar=6.9 kPa=0.07 kg/cm²=0.7 m (W.C)

ILLUSTRATED PARTS BREAKDOWN

NO.	DESCRIPTION
1	Filter Body
2	Coarse Screen Assembly
3	Fine Screen Assembly
4	Dirt Collector Assembly
5	Worm Gear Motor
6	Rinse Valve
7	Air Valve
8	Cover
9	Cover Gasket
10	Control Box

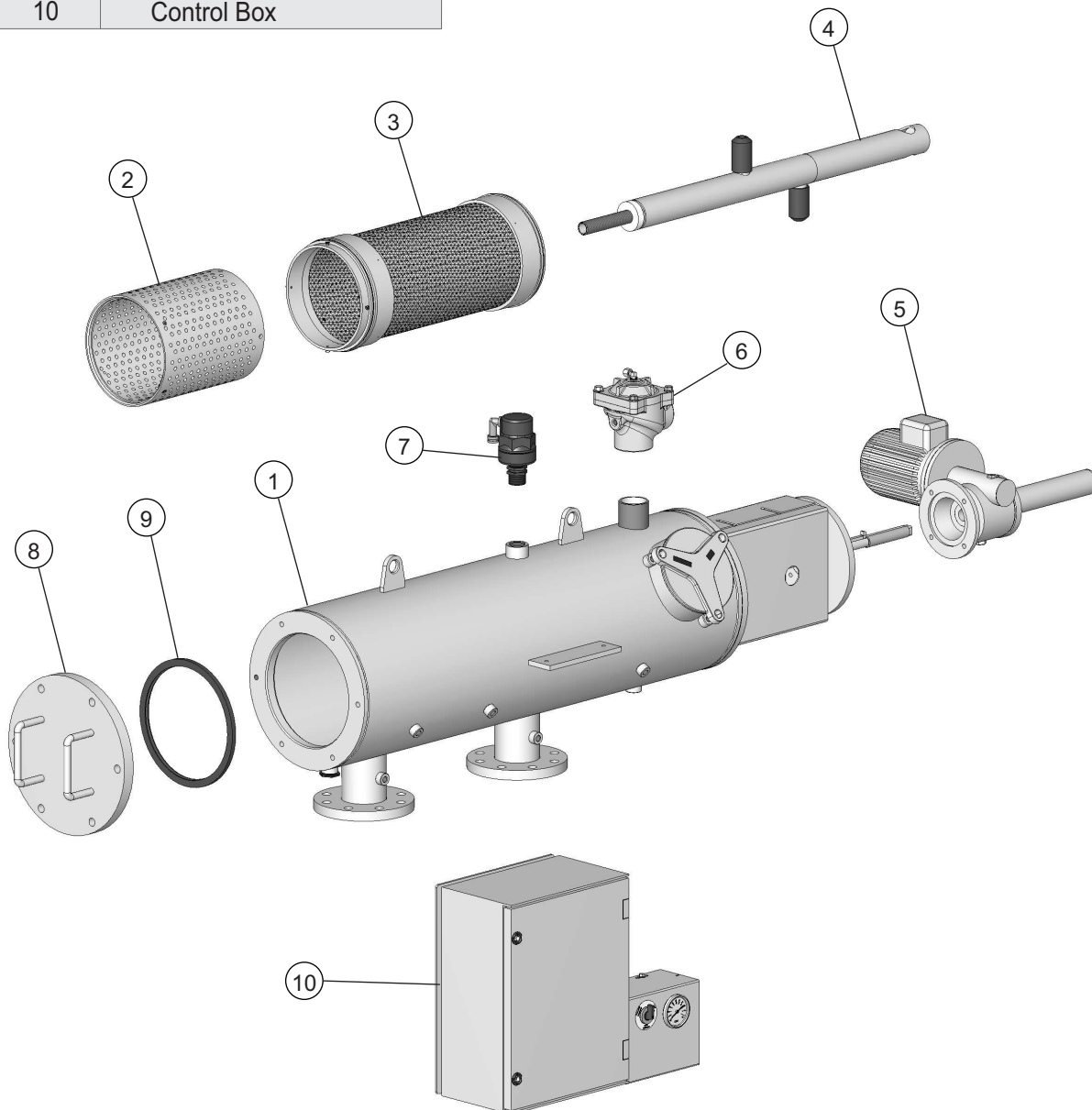

GENERAL INSTRUCTIONS

Operation

- The **Odismatic[®] Electric Filter** is equipped with an automatic cleaning system electrically operated which includes: Suction System for cleaning the screen, Electric Motor with worm gear to drive the suction nozzles in a helical movement, and PLC to control the cleaning process.
- The cleaning cycle is activated when the differential pressure across the screen reaches 0.5 bar (7.5 psi) with a timer backup.
- The minimum working pressure is 2 bar (30 psi).
- The maximum working pressure is 10 bar (150 psi).

Installation

The **Odismatic[®] Electric Filter** can be installed in any position, although for ease of maintenance, a horizontal installation is recommended.

- For best results, the filter should be installed as near as possible to the system it is required to protect. However, if low filter inlet pressure is a concern, either before or during flushing, the filter may need to be installed closer to the pressure source.
- Ensure that the upstream pipe size from pressure source to filter is equal to or greater than filter inlet size.
- It is recommended to install inlet and outlet isolation valves for easy maintenance.
- In situations where a constant supply of water is required downstream during filter servicing it is recommended to install Inlet and bypass valves. Note that this also applies in installation of bypass units.
- It is recommended to install a check valve downstream of the filter to prevent reverse flow and to protect the filter from water hammer.
- An Air-Release Valve must be installed on top of the inlet manifold.
- Ensure that the filter is mounted in the proper direction of flow as indicated by the arrows on the filter housing.
- A drain line should be attached to each flushing valve. For details see Technical Manual.
- If pressure is not controlled effectively a pressure relief valve must be inserted before the filtering installation.
- Connect power supply

Start-Up

1. Slowly open the inlet valve to the filter allowing the filter to pressurize.
2. Check for any external leakage and eliminate.
3. Check to ensure that the filter inlet pressure is higher than 2 bar (30 psi).
4. Slowly open the outlet valve of the filter.
5. Initiate a manual flushing cycle by depressing the manual flushing button on the electrical control box and see the movement of the screw.

Periodic Cleaning

- Initiate a manual flushing cycle and check for proper filter function by observing the pressure. This step should be performed for all individual filters in multiple installations.
- Check coarse screen and clean as required.
- Filters equipped with by-pass should be engaged at least once a month. This will clean the valve seat of any accumulated dirt, as well as ensuring proper by-pass operation.

WARNING

- **Do not tighten or open cover during operation or under pressure.**

Maintenance

- Each filter is supplied with Technical Manual for detailed maintenance instructions, as well as assembly, installation and operation instructions.
- Apply a layer of grease to bolt threads once a year.
- Apply Molykote grease to the screw of the drive assembly every 3 months.
- Clean Control Filter every 3 month at least.
- Any damage to the protective coating of filter must be repaired without delay.
- Prior to the application of the protective paint, thoroughly clean the damaged spot with the wire brush.

PACKING / SHIPPING DATA
Metric Units

Model	Inlet / Outlet (inch)	Gross * Weight (kg)	Packaging	Gross Volume (m ³)
86302	2"	221	Packed on a pallet	1.5
86303	3"	226	Packed on a pallet	1.5
86304	4"	240	Packed on a pallet	1.7
86306	6"	248	Packed on a pallet	1.7
86308	8"	344	Packed on a pallet	2.3
86310	10"	355	Packed on a pallet	2.3
86312	12"	405	Packed on a pallet	2.6
86314	14"	435	Packed on a pallet	2.6

U.S. Units

Model	Inlet / Outlet (inch)	Gross * Weight (lbs)	Packaging	Gross Volume (cu.ft)
86302	2"	487	Packed on a pallet	53
86303	3"	498	Packed on a pallet	53
86304	4"	529	Packed on a pallet	60
86306	6"	547	Packed on a pallet	60
86308	8"	760	Packed on a pallet	81
86310	10"	783	Packed on a pallet	81
86312	12"	893	Packed on a pallet	92
86314	14"	960	Packed on a pallet	92

* Gross weight includes packaging materials

How To Order *OdisMatic*® Electric Filter

1. Type of filter required.
2. Catalog Number of filter.
3. Preferred mesh grade.
4. Min. / Max. pressure.
5. Maximal Flow rate.
6. Electricity.
7. Additional accessories: Nipples/Valves/Pilots/Relays/Manifolds/Pressure Gauges.
8. Other than standard material, required for filter body and cover.
9. Special Coating Requirements.